

A large yellow excavator is shown in the process of loading a yellow dump truck at a mining site. The excavator's bucket is positioned over the truck's bed, and it appears to be depositing material. The background features a rocky, open-pit mine under a blue sky with scattered white clouds. The scene is framed by a dark brown diagonal banner on the left and bottom right.

Developing a  
Growing, Open Pit  
Lead-Silver Project in  
Western Australia

Investor Presentation - 12 October 2020

**Pacifico**  
Minerals Ltd

# DISCLAIMER

## Forward-Looking Statements

Certain statements in the presentation are or may be “forward-looking statements” and represent the Company’s intentions, projections, expectations or beliefs concerning, among other things, future operating and exploration results or the Company’s future performance. These forward-looking statements speak, and the presentation generally speaks, only at the date hereof. The projections, estimates and beliefs contained in such forward looking statements necessarily involve known and unknown risks and uncertainties, and are necessarily based on assumptions, which may cause the Company’s actual performance and results in future periods to differ materially from any express or implied estimates or projections.

## General Disclaimer

The information in this presentation remains subject to change without notice. This presentation may contain information (including information derived from publicly available sources) that has not been independently verified by the Company.

## Not an Offer

This presentation is for information purposes only. The presentation does not comprise a prospectus, product disclosure statement or other offering document under Australian law. The presentation does not constitute or form part of any invitation, offer for sale or subscription or any solicitation for any offer to buy or subscribe for any shares in Pacifco Minerals Limited.

## No Liability

Pacifco Minerals Limited has prepared this document based on information available at the time of preparation. No representation or warranty, express or implied is made as to the fairness, accuracy or completeness of the information, opinions and conclusions contained in this presentation. To the maximum extent permitted by law, Pacifco Minerals Limited, its related bodies corporate and the officers, directors, employees, advisers and agents of those entities do not accept any responsibility or liability for any loss arising from the use of the presentation or its contents or otherwise arising in connection with it.

## Competent Person Statements

The Australasian Code for Reporting of Exploration Results, Mineral Resources and Ore Reserves (the ‘JORC Code’) sets out minimum standards, recommendations and guidelines for Public Reporting in Australasia of Exploration Results, Mineral Resources and Ore Reserves.

Information included in this presentation relating to Mineral Resources, Ore Reserves, Production Targets and Financial Forecasts has been extracted from the Mineral Resource Estimate dated 2 June 2020 and the Pre-Feasibility Report and Ore Reserve Statement dated 25 August 2020, both available to view at [www.pacificominerals.com.au](http://www.pacificominerals.com.au). The Company confirms that it is not aware of any new information or data that materially affects the information included in either the Mineral Resource Estimate or the Ore Reserve Statement and that all material assumptions and technical parameters underpinning the estimates continue to apply and have not materially changed. The Company confirms that the form and context in which the Competent Person’s findings are presented have not been materially modified from the Mineral Resource Estimate or the Ore Reserves Statement.

The information in this release that relates to Exploration Results is based on information prepared by Dr Simon Dorling. Dr Dorling is a member of the Australasian Institute of Geoscientists (Member Number: 3101). Dr Dorling has sufficient experience which is relevant to the style of mineralisation and type of deposit under consideration and to the activity which they are undertaking to qualify as a Competent Person as defined in the 2012 Edition of the JORC Australasian Code for Reporting of Exploration Results, Mineral Resources and Ore Reserves. Dr Dorling consents to the inclusion in the release of the matters based on their information in the form and context in which it appears.



# INVESTMENT RATIONALE

- ✓ **Australia's largest undeveloped, near-surface Lead-Silver-Zinc deposit**  
Granted mining leases, EPA approved<sup>1</sup>, 150km from Wyndham Port in Western Australia
- ✓ **Low Risk Operation located in a Tier 1 Mining Jurisdiction**  
Initial 10-year Open cut mine plan underpinned by 92% Reserves and low cash operating cost
- ✓ **Rare ASX exposure to Silver markets**  
1.5 Million ounces per annum of Silver production
- ✓ **Fully Funded through to a Decision to Mine**  
A\$11.5m cash on hand to fund Resource expansion and Definitive Feasibility Study ("DFS")
- ✓ **Impressive Project Economics**  
Pre-Tax NPV<sub>8</sub> A\$303m, Pre-Tax IRR 46%, ~1.6-year payback from start of production
- ✓ **Near term opportunities to add significant value**  
Mine Life upside supported by a demonstrated ability to increase Resource size and confidence

1. Section 45C change proposal to be submitted to the EPA to reflect advancements



# CORPORATE SUMMARY

## Capital structure (as at 9 October 2020)

Share Price	A\$0.018 / share
Shares on Issue	3,476 million shares
Market Capitalisation	A\$63 million
Debt	Nil
Cash	A\$11.5 million
Options & Perf. Rights	427 million <sup>1</sup>

## Board Composition and Management

Chairman	Gary Comb
Managing Director and CEO	Simon Noon
Non-Exec. Director	Richard Monti
Non-Exec. Director	Andrew Parker
Project Manager	Kevin Reynolds
Exploration Manager	Simon Dorling

1. 351 million Listed Options exercisable at \$0.015 exp 21 Nov 20.  
32.5 million Unlisted Options exercisable at \$0.015 exp 21 Nov 20  
43.5 million Performance Rights

## Pacifico Minerals Limited (ASX:PMY)

- ✓ **ASX-listed base metal developer and explorer.**
- ✓ **Experienced Board and Management with a proven track record in mineral exploration and mine development.**
- ✓ **Resource inventory<sup>2</sup> comprising 1.5Mt of Lead and 54Moz of Silver.**
- ✓ **Top 10 shareholders hold 35% of issued capital.**

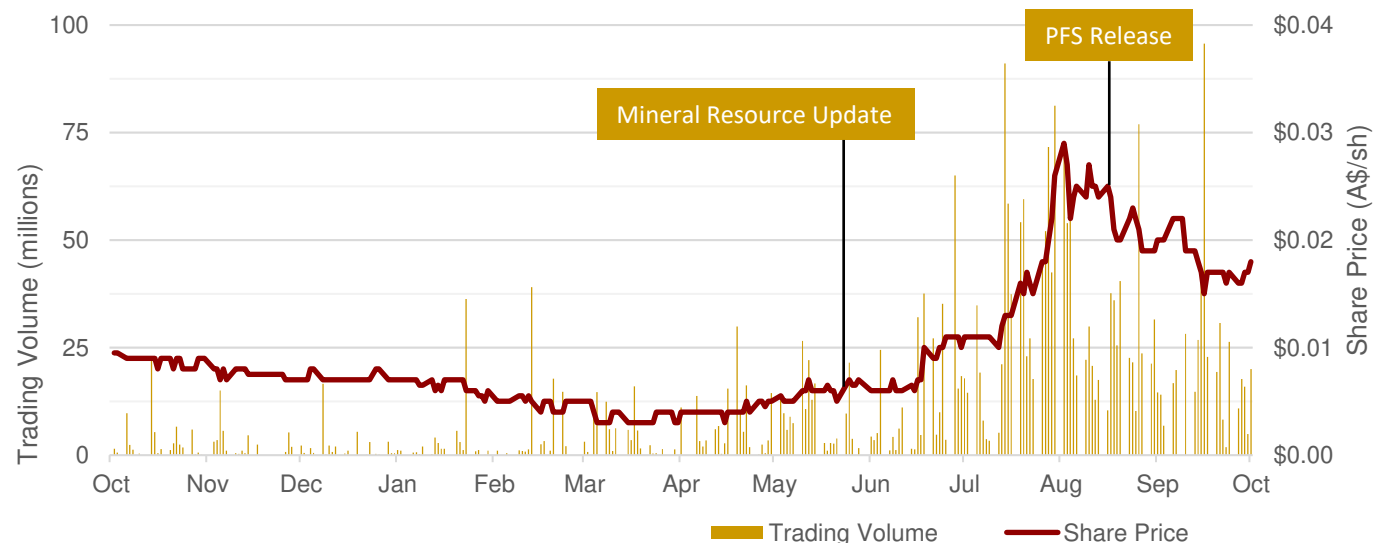

2. See Slide 6 for full Mineral Resource Estimate



# PROJECT HIGHLIGHTS

## Sorby Hills Lead-Silver-Zinc Project

**Australia's largest undeveloped, near-surface Lead-Silver-Zinc deposit.**

- ✓ **75%/25% Joint Venture Partnership with China's largest Lead smelter and Silver producer, Henan Yuguang Gold and Lead Co. Ltd.**
- ✓ **Granted pre-native title mining tenements.**
- ✓ **Large shallow Resource with significant growth potential.**
- ✓ **Open Pit Reserves of 494kt Lead and 17.6Moz Silver<sup>1</sup> and growing.**
- ✓ **Located proximal to existing infrastructure:**
  - ~50km north-east of Kununurra;
  - ~150km by existing sealed road to Wyndham Port; and
  - Opportunity to access grid power.

**Fully funded DFS underway.**

*1. See Slide 8 for full Reserve Estimate*

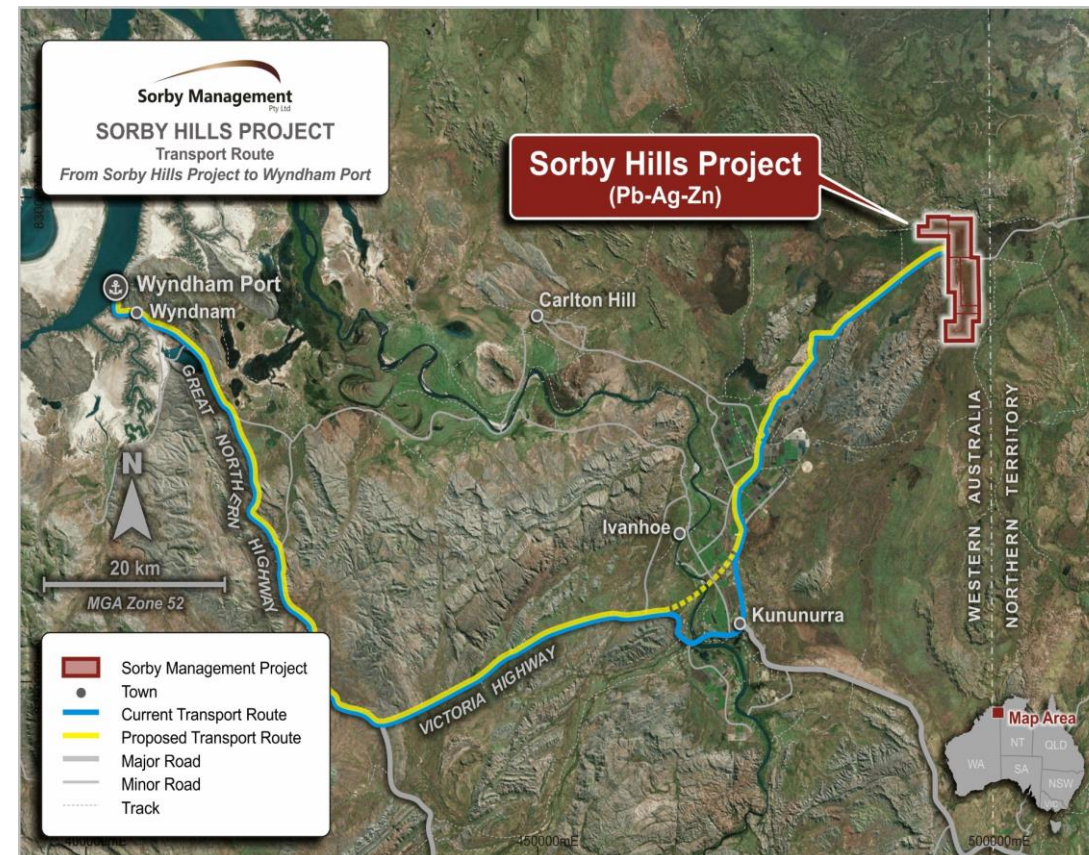

*Image: Location of the Sorby Hills Project relative to Kununurra and Wyndham Port*

# MINERAL RESOURCE ESTIMATE

Large shallow Resource comprising six gently dipping Lead-Silver deposits with well defined geology

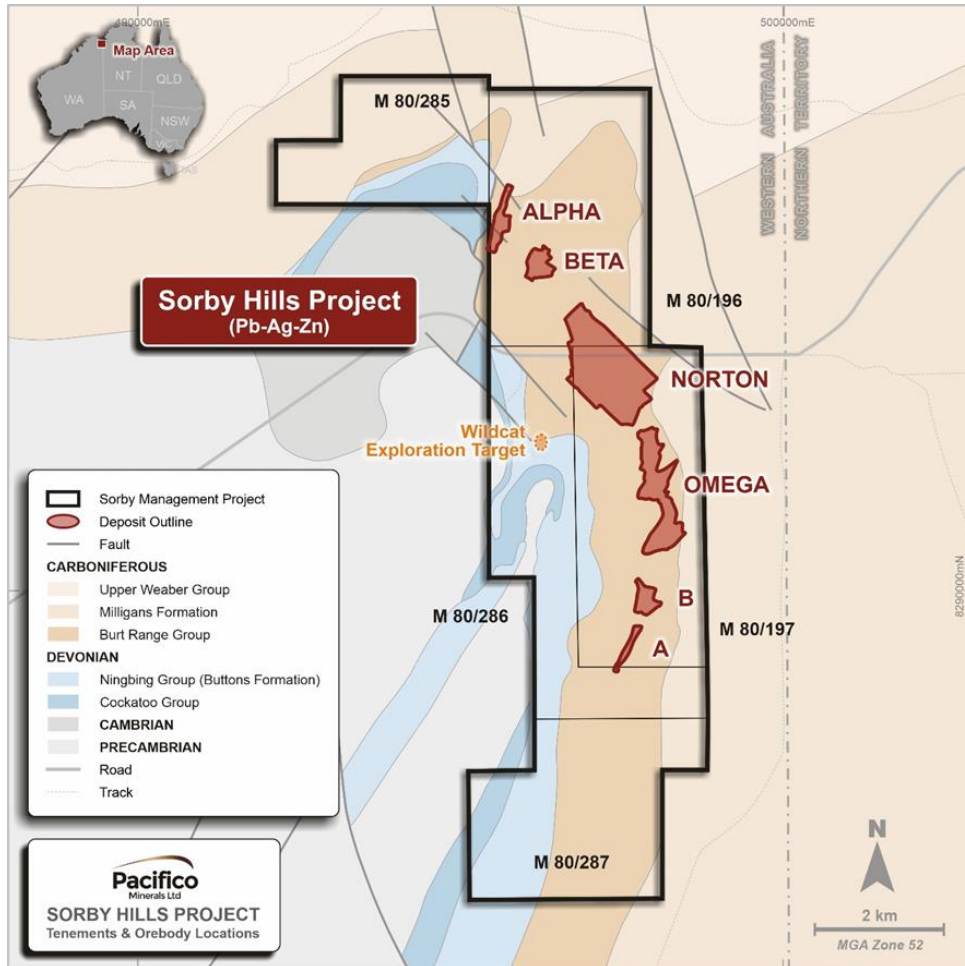

Deposit	Mt	Pb (%)	Ag (g/t)	Zn (%)
A	0.6	6.1	32	1.2
B	1.8	4.3	24	0.3
Omega	15.8	3.5	32	0.4
Norton	20.6	2.8	37	0.4
Alpha	2.0	3.1	67	1.0
Beta	3.3	4.6	61	0.4
<b>Total</b>	<b>44.1</b>	<b>3.3</b>	<b>38</b>	<b>0.5</b>
<b>Measured</b>	<b>7.1</b>	<b>4.3</b>	<b>57</b>	<b>0.4</b>
<b>Indicated</b>	<b>13.7</b>	<b>3.3</b>	<b>31</b>	<b>0.4</b>
<b>Inferred</b>	<b>23.4</b>	<b>3.0</b>	<b>36</b>	<b>0.5</b>

Reported at cut-off of 1% Pb (Pb domains only)

The information presented above is extracted from the report entitled "Mineral Resource Update Sorby Hills Pb-Ag-Zn Project" released on 2 June 2020 and is available to view on [www.pacificominerals.com.au/](http://www.pacificominerals.com.au/).

Image: Location of the Sorby Hills deposits and mining tenements relative to local geology



## PFS highlights a technically robust project with impressive economics

The PFS highlights the **low-risk** nature of the Sorby Hills Project with a **well-defined** large-scale Mineral Resource, conventional crush-mill-float processing circuit, **high metal recoveries** and **key approvals received**.

- ❖ Initial 10-Year Mine life processing 14.8Mt ore
- ❖ 50kt Lead and 1.5Moz Silver production per annum<sup>1</sup>
- ❖ US\$0.40/lb Lead C1 cash cost
- ❖ Average Life of Mine EBITDA A\$75m per annum  
(A\$127m per annum over the first 2 years of production)
- ❖ A\$183m Upfront Capex including A\$20m contingency
- ❖ Pre-Tax NPV<sub>8</sub> of A\$303m<sup>2</sup> and Pre-Tax 46% IRR<sup>2</sup>
- ❖ 1.6-year payback<sup>2</sup>



The quality and detail included in the PFS allows for a seamless transition into the DFS and early discussions with lenders.

1: Life of mine average

2: NPV based on 10-year average commodity prices. Lead US\$0.95/lb, Silver US\$21.10/oz. AUD:USD FX rate of 0.70

# ORE RESERVE AND MINE PLAN

## A low-risk Mine Plan underpinned by 92% Ore Reserves

Classification	Mt	Pb (%)	Pb (kt)	Ag (g/t)	Ag (Moz)
Proved	6.8	4.1	275	53.0	11.5
Probable	6.9	3.2	219	27.6	6.1
<b>Total</b>	<b>13.6</b>	<b>3.6</b>	<b>494</b>	<b>40.2</b>	<b>17.6</b>

Reported at cut-off of 1.5% Pb

## Base Case Quarterly Mine Plan

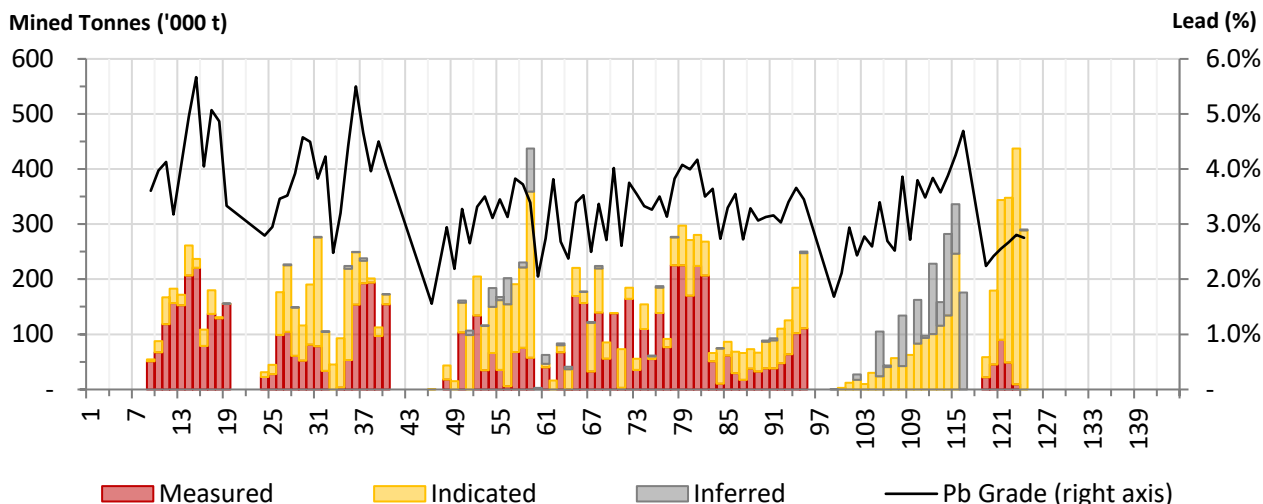

The **PFS Base Case** incorporates the mining of 14.8Mt of ore over an **initial 10-year mine life** from four deposits, namely Omega, A, B and southern portion of Norton.

- ✓ Mineralisation from 20m.
- ✓ Flat topography and easy free dig in first 18m.
- ✓ Life of Mine Strip Ratio of 8.0x (volumetric basis).
- ✓ Ministerial and WA Environmental Protection Authority (“EPA”) approval for an open pit mine and infrastructure<sup>1</sup>.

Section 45C change proposal to be submitted to the EPA to reflect advancements. Refer ASX announcement 25 August 2020 for further information



## Conventional processing route producing a high-quality concentrate

Production Summary	
Plant Process	Crush, Mill and Float
Plant Throughput	1.5Mt p.a.
Average Feed Grade	3.6% Lead, 39.5 g/t Silver
Average Lead Recovery	93.3%
Average Silver Recovery	80.3%
Total Production	807,000 dmt concentrate
Average Production	81,000 dmt concentrate p.a.
Average Grade	62% Lead, 580 g/t Silver
<b>Average Lead</b>	<b>50kt p.a.</b>
<b>Average Silver</b>	<b>1.5Moz p.a.</b>

dmt = dry metric tonnes

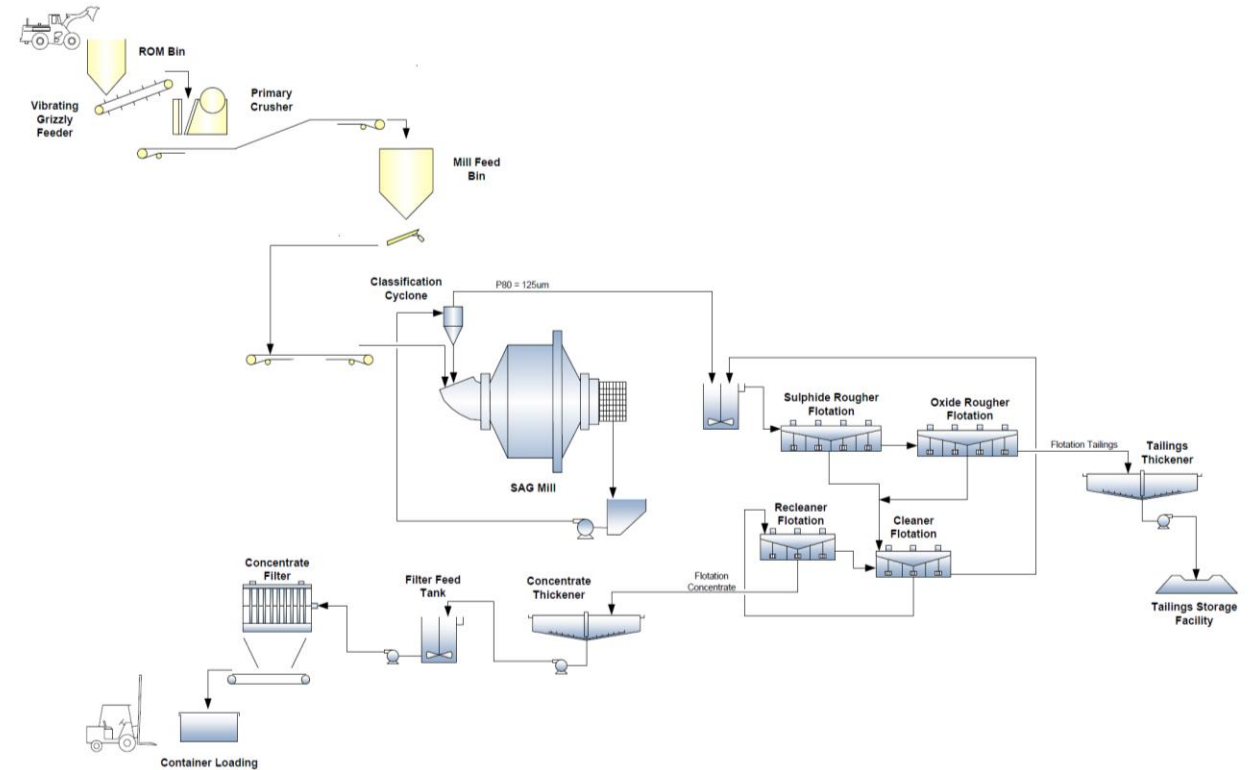

Image: Sorby Hills processing circuit

# VALUE ADDING OPPORTUNITIES

Demonstrated ability to efficiently increase Resource size and confidence with each drilling program

Pacifico has undertaken three phases of drilling that have:

- ✓ increased the total Resource tonnage by more than 50%; and
- ✓ approximately tripled the contained metal classified as a Measured and Indicated Resource.

Phase IV Drill program underway.

Ongoing 68 drill hole (5,200m) program focused on:

- near mine Resource extensions and continuity testing; and
- exciting near mine exploration targets.

Drilling results expected to begin flowing by November 2020 with a Mineral Resource Estimate update planned for Q1 2021.

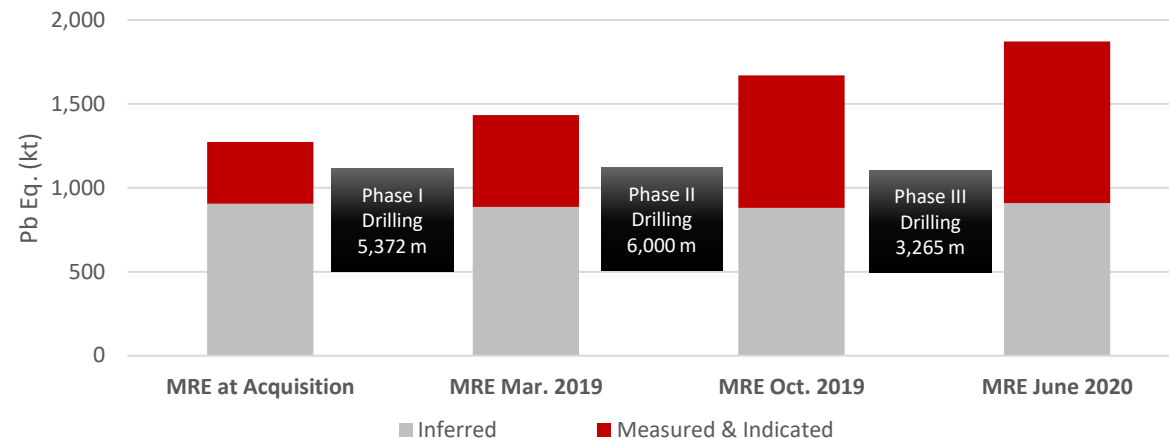

Image; Mineral Resource Estimate growth since acquisition in 2018

<sup>2</sup>Mineral Resource Estimates reported at 1.0% Pb cut-off, Zn is not included. <sup>3</sup>Refer to appendix for Pb Equivalent calculations

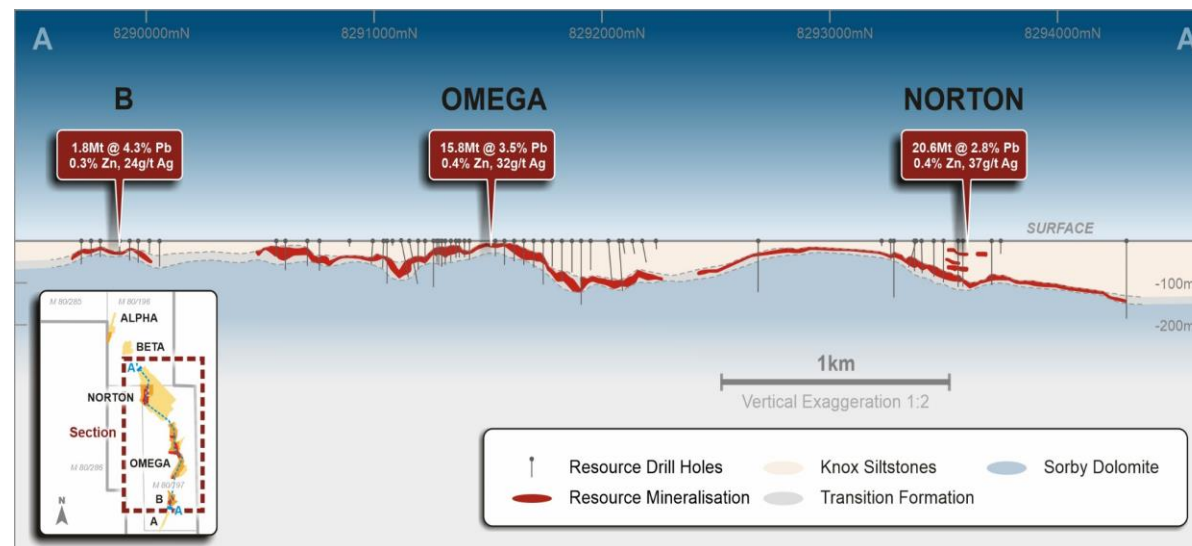

Image: Long section looking west. Red blocks represent mineralisation from the MRE block model.



# VALUE ADDING OPPORTUNITIES

## High quality near mine drilling targets

- ✓ Planned drilling is expected to confirm continuity between Norton and Omega deposits.
- ✓ Extension of the gravity survey to cover full tenement package.
- ✓ Four wildcat drillholes in 2018 intersected **continuous shallow mineralisation**. Follow up diamond drilling planned as part of current drilling program – **possible link to Norton**.

Alpha, Beta and northern portion of Norton were **excluded from the PFS Mine Plan** to ensure the Project does not materially step outside the EPA approved development zone.

## Significant Drilling Results to date

- **22.0m at 8.8% Pb, 52g/t Ag, 0.3% Zn** from 68m (ACD082).
- **20.0m at 7.3% Pb, 56g/t Ag, 0.4% Zn** from 11m (ACD046).
- **11.7m at 10.8% Pb, 105 g/t Ag, 0.4% Zn** from 75.7m (AF005).
- **14.0m at 13.0% Pb, 89g/t Ag, 1.0% Zn** from 24m (ACD080).
- **21.0m at 5.0% Pb, 21g/t Ag, 0.5% Zn** from 23m (ACD056).
- **23.0m at 9.0% Pb, 88g/t Ag, 1.2% Zn** from 59m (ACD071).
- **21.0m at 5.0% Pb, 21g/t Ag, 0.5% Zn** from 23m (ACD056).
- **10.0m at 7.16% Pb, 383g/t Ag, 0.43% Zn** from 110m (SHPDA31).
- **10.0m at 6.6% Pb, 53g/t, Ag 0.9% Zn** from 92m (Norton - AI010).
- **12.3m at 5.5% Pb, 42g/t, Ag 0.2% Zn** from 90m (Norton - AI011).

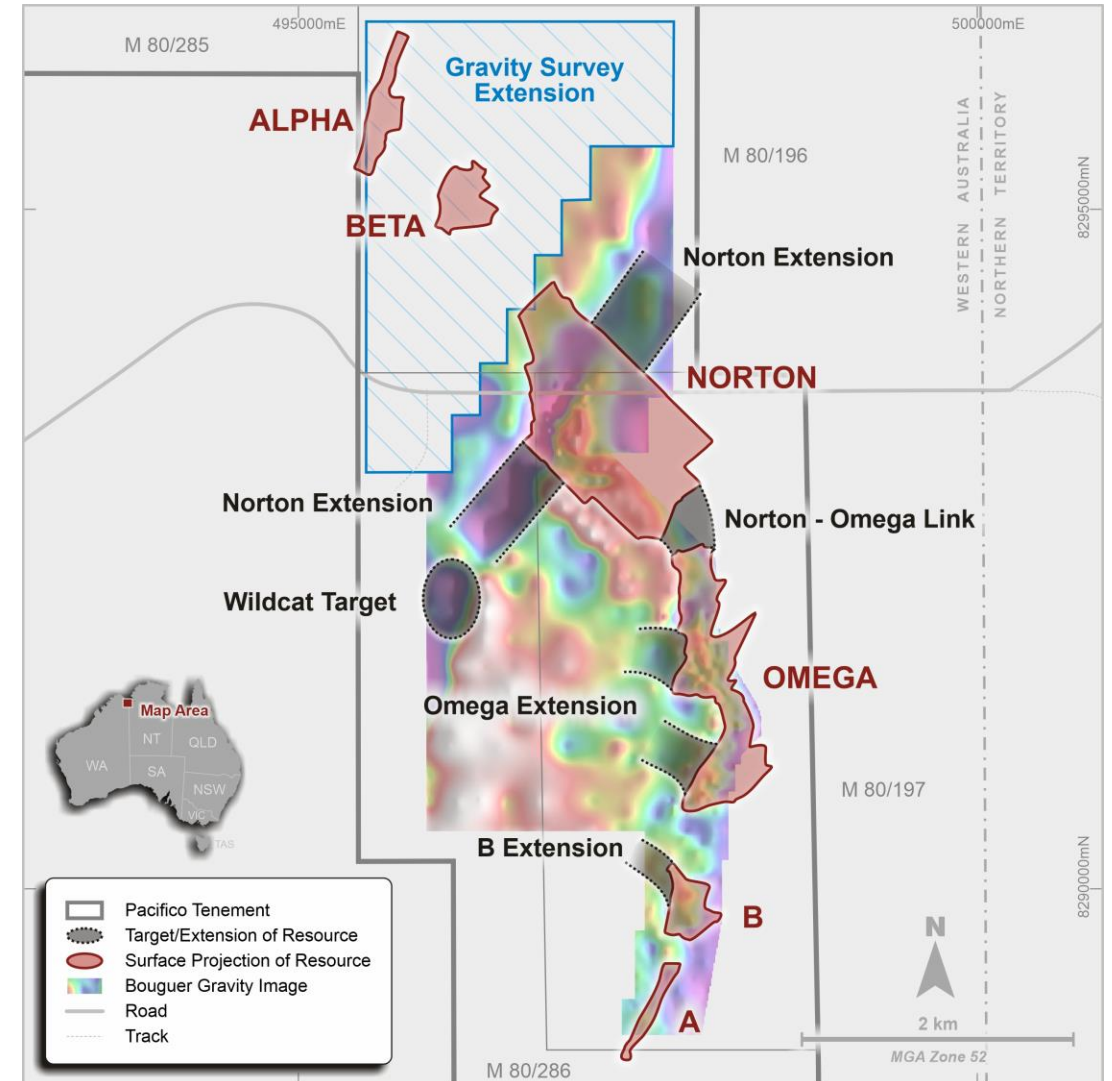

# VALUE ADDING OPPORTUNITIES

The incorporation of a DMS circuit would allow for the economic treatment of lower grade ore that would otherwise be classified as waste

- The PFS considered an **alternative processing option** whereby low-grade ore is beneficiated via a parallel DMS circuit to produce a product that supplements the high-grade direct flotation feed.
- The study demonstrated:
  - ✓ increased ore throughput;
  - ✓ *enhancement of sub-economic ore grade by 2.7x Lead and 2.4x Silver; and*
  - ✓ *enhanced flotation feed grade.*

The encouraging results of the DMS Option clearly warrants further investigation during DFS.

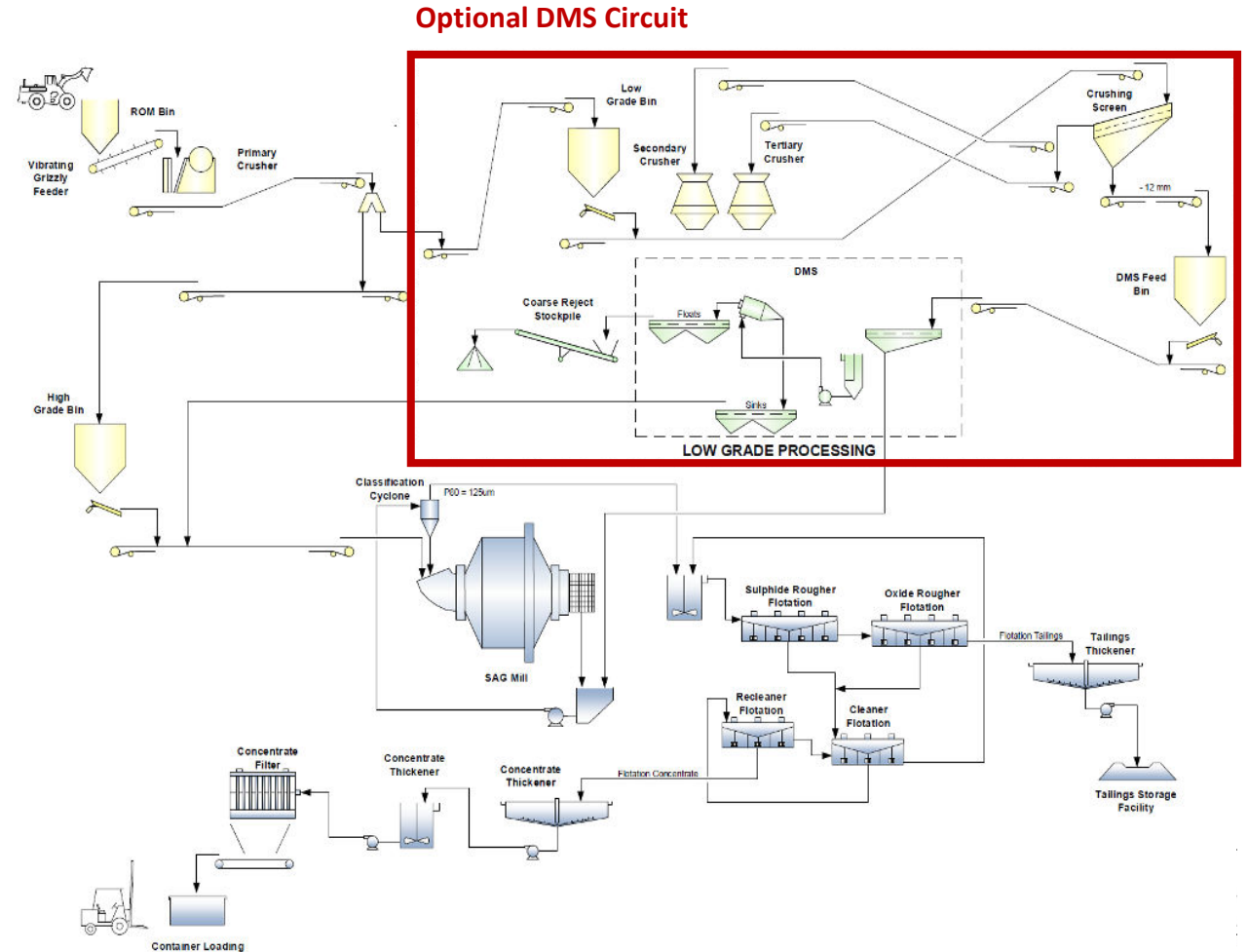



# VALUE ADDING OPPORTUNITIES

## Eight Mile Creek - Exploration Licence E80/5317

- ✓ **100% owned by Pacifico.**
- ✓ **Covers 217 km<sup>2</sup> of relatively underexplored tenure** immediately south of Sorby Hills.
- ✓ **30 km of along-strike geology** highly prospective for deposits similar to Sorby Hills.
- ✓ **A native title and mineral exploration agreement has been executed** for the tenement laying the foundation for a productive and collaborative relationship with the traditional owners and providing employment and economic opportunities.

**Strategic landholding paving the way for a long-term future for Pacifico within the region.**

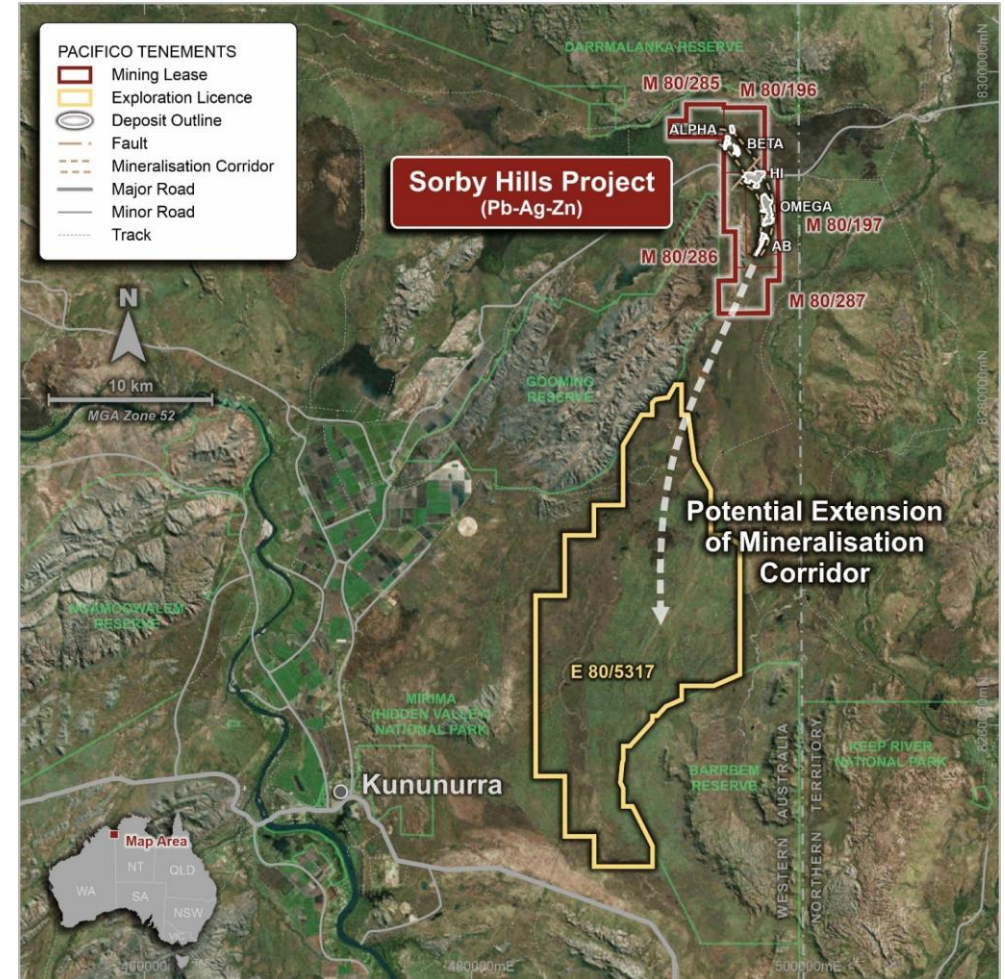

Image: PMY 100% owned E80/5317 to the south of the Sorby Hills JV Project.

## Pacifco has engaged with the Northern Australia Infrastructure Facility (“NAIF”) in regard to financing for the Project

- NAIF is an **Australian Federal Government** organisation with an aggregate of **A\$5 billion of debt finance** which may be lent on **concessional terms** to support infrastructure development that generates public benefit for northern Australia.
- NAIF undertakes a **four-stage assessment process** when considering projects that it will finance.
- **Sorby Hills has passed through Stage 1 and Stage 2** and is now within NAIF’s Due Diligence Stage.
- Subject to Sorby Hills successfully passing through Stage 3 and Stage 4, **NAIF has the ability to fund up to 100% of the Project Debt** providing the Commonwealth overall does not have the majority risk in a project.
- Pacifco will continue to assist NAIF with its required due diligence investigations regarding participation in any potential debt facilities to fund Sorby Hills’ development. At this stage, NAIF has not made any decision to offer finance and there is no certainty that an agreement will be reached between the parties.





# LEAD AND SILVER IN THE CLEAN ENERGY ECONOMY

## Lead

- **Lead batteries** are a key in the transition to a low carbon economy, applications include:
  - **Electric Vehicles** 12V lead batteries power the EV battery management and safety systems. 'Stop-start' technology requires batteries with 25% more lead<sup>1</sup>;
  - **E-bikes** - Roughly 15 million are sold each year in China alone<sup>2</sup>; and
  - **5G network base stations** - high lead consuming application with a Chinese production. increase of 134% in 2018<sup>1</sup>.
- Predicted growth in lead demand - **CAGR of 6.74%** between 2018 and 2022<sup>3</sup>.

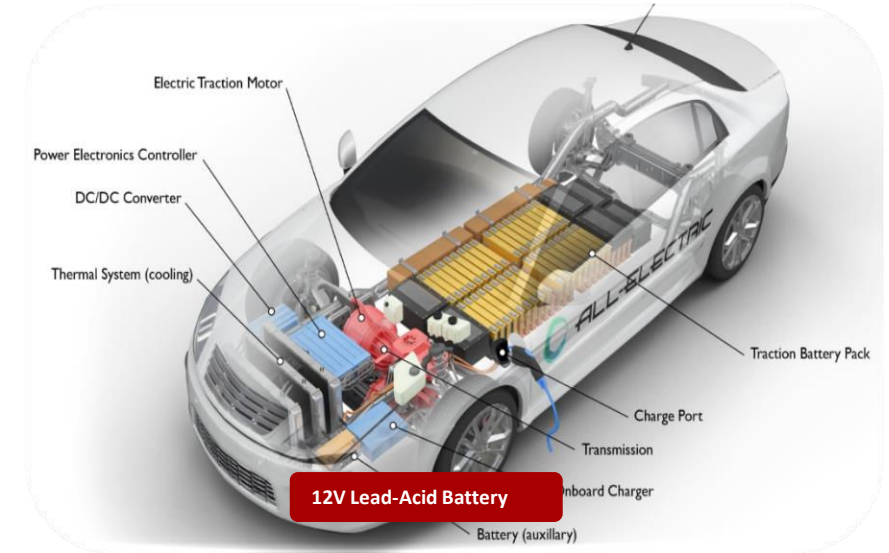

## Silver

- Silver's industrial applications, particularly in emerging green industries, **provides a supply-demand overlay to the traditional storage of wealth thematic.**
- **Silver is the best-known conductor of electricity.**
- **Solar Photovoltaics (PV) cells** – Silver's use in photovoltaics grew by 7% in 2019<sup>4</sup>.
- Silver demand edged higher in 2019 to 991.8 Moz, up 0.4% whilst production declined by 1.3%<sup>4</sup>.



1. The Assay Group Mining Magazine (<https://www.theassay.com/articles/lead-5-things-to-look-for-in-2019>) , 2. ASX: G1A Feb 2019 Origin: Wood Mackenzie, 3. Business Wire ([www.businesswire.com/news/home/20180803005303/en/Global-Lead-Market-Analysis-Trends-Forecasts-2018-2022](http://www.businesswire.com/news/home/20180803005303/en/Global-Lead-Market-Analysis-Trends-Forecasts-2018-2022)), 4. The Silver Institute [www.silverinstitute.org](http://www.silverinstitute.org)

# EXPOSURE TO THE SILVER MARKET

The recent surge in the price of Silver has been reflected in the Pacifco share price demonstrating the significance of the precious metal in the value of Sorby Hills

## Relevance for shareholders

- ✓ PMY market price likely to continue to reflect Silver price movement.
- ✓ Robust Project economics supported by a diversified revenue stream increasingly driven by industrial demand.





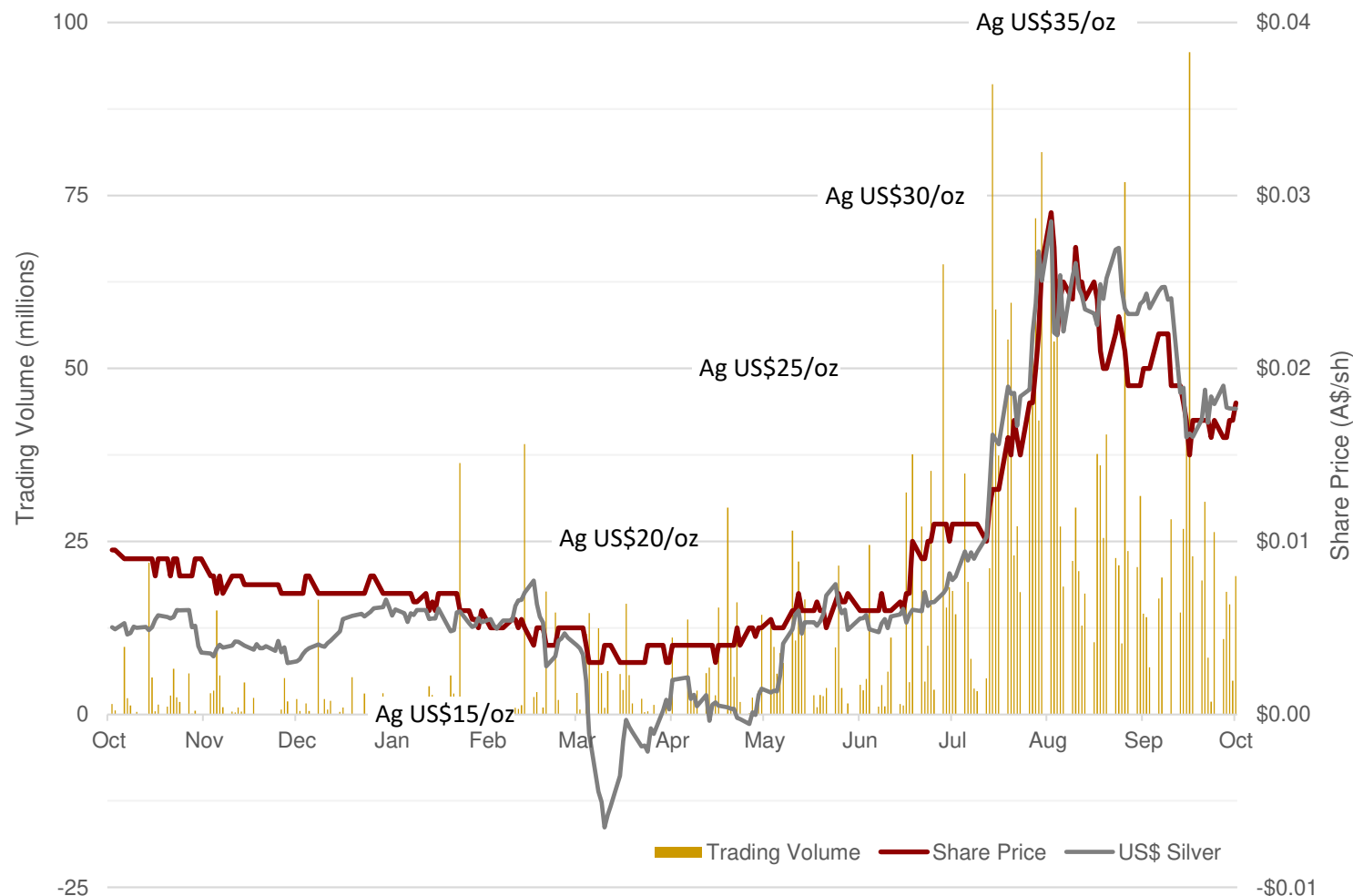

The Sorby Hills Mineral Resource Estimate of 44.1Mt at 3.3% Pb, 38 g/t Ag and 0.5% Zn equates to **44.1Mt at 128 g/t Ag Eq.**

*Zn is not included in Ag Eq calculation, Refer to appendix for Ag Equivalent calculations  
See Slide 6 for full Mineral Resource Estimate*



# DEVELOPMENT TIMELINE PROVIDING SIGNIFICANT NEWSFLOW

On track to become a significant lead-silver producer in Western Australia

Milestone	Status	CY2021				
		CY2020	Q1	Q2	Q3	Q4
		Q4	Q1	Q2	Q3	Q4
Updated Resource Estimate	✓					
Pre Feasibility Study	✓					
Maiden Ore Reserve Estimate	✓					
Securing Funds to reach Decision to Mine	✓					
Drilling and Updated Resource Estimate	Ongoing					
Definitive Feasibility Study	Ongoing					
Permitting and Approvals	Ongoing					
Financing and Offtake Process	Ongoing					
Front End Engineering Design	Start Q3 2021					
Decision to Mine Project Award	Q4 2021					





**THANK YOU**

Simon Noon – Managing Director

[info@pacificominerals.com.au](mailto:info@pacificominerals.com.au)

[www.pacificominerals.com.au](http://www.pacificominerals.com.au)





## APPENDIX

# PFS CAPITAL AND OPERATING COSTS

Capital Cost Estimate	
Capital Item	A\$M
Pre Production Mining	24.3
Process Plant incl. EPC fee	105.4
Infrastructure	20.5
Owners Costs	13.1
Contingency	19.6
<b>Total Pre-Production CAPEX</b>	<b>182.8</b>
Sustaining Capital	32.2
<b>Total CAPEX</b>	<b>215.0</b>
Throughput Capacity - Mtpa	1.50
Concentrate Produced - '000 dmt	806.8
<b>Upfront Capex A\$ per tonne throughput capacity</b>	<b>122</b>
<b>Upfront Capex A\$ per tonne concentrate</b>	<b>227</b>

Operating Cost Estimate <sup>1</sup>				
Cost Centre	A\$M	A\$/t ore	A\$/lb <sup>2</sup>	US\$/lb <sup>2</sup>
Mining	<b>347</b>	<b>23.48</b>	<b>0.33</b>	<b>0.23</b>
Processing	292	19.80	0.28	0.20
G & A	107	7.28	0.10	0.07
Transport	108	7.35	0.10	0.07
Lead Treatment Charges	161	10.93	0.15	0.11
<b>C1 Costs excl. Credits</b>	<b>1,016</b>	<b>68.85</b>	<b>0.97</b>	<b>0.68</b>
Silver Revenue	(431)	(29.21)	(0.41)	(0.29)
Silver Refining Charge	20	1.38	0.02	0.01
<b>C1 Costs incl. Credits</b>	<b>606</b>	<b>41.03</b>	<b>0.58</b>	<b>0.40</b>
Lead Royalty	59	4.01	0.06	0.04
Silver Royalty	10	0.70	0.01	0.01
Sustaining Capex	32	2.18	0.03	0.02
<b>AISC<sup>3</sup></b>	<b>707</b>	<b>47.91</b>	<b>0.67</b>	<b>0.47</b>

1. PFS assumptions include lead price US\$2,095/t, and silver price US\$21.1/oz and A\$1=US\$0.70.

2. Unit costs quoted as pounds (lb) Lead Payable, 3. No Interest Charge has been assumed



# PFS LIFE OF MINE METRICS

Item	Unit	Base Case
<b><u>Economic Assumptions</u></b>		
Lead Price	US\$/t	2,095
Silver Price	US\$/oz	21.10
Exchange Rate	A\$:US\$	0.70
<b><u>Physicals</u></b>		
Life of Mine (LOM)	Years	9.9
Mined Ore	kBCM	5,161
Strip Ratio	Waste : Ore	8.0x
Processed Tonnes	kt	14,760
Processed Lead Grade	%	3.63
Processed Silver Grade	g/t	39.5
Lead Recovery	%	93.3
Silver Recovery	%	80.3
Recovered Lead	kt	500.2
Recovered Silver	Moz	15.1
Concentrate Produced	kdmt	806.8
<b>Payable Lead</b>	<b>kt</b>	<b>475.2</b>
<b>Payable Silver</b>	<b>Moz</b>	<b>14.3</b>

Item	Unit	Base Case
<b><u>Cash Flow</u></b>		
Lead Revenue	A\$M	1,422.3
Silver Revenue	A\$M	431.1
<b>Gross Revenue</b>	<b>A\$M</b>	<b>1,853.3</b>
Royalties	A\$M	(69.5)
TC/RC & Transport	A\$M	(290.3)
<b>Net Revenue</b>	<b>A\$M</b>	<b>1,493.6</b>
On Site Operating Costs	A\$M	(746.3)
<b>Net Operating Cash Flow</b>	<b>A\$M</b>	<b>747.3</b>
Upfront Capital Cost	A\$M	(182.8)
Sustaining Capital Costs	A\$M	(32.2)
<b>Net Project Cash Flow (Pre-Tax)</b>	<b>A\$M</b>	<b>532.3</b>
<b><u>Value Metrics</u></b>		
<b>Pre-Tax NPV<sub>8</sub></b>	<b>A\$M</b>	<b>303.4</b>
<b>Pre-Tax IRR</b>	<b>%</b>	<b>46</b>
<b>Pre-Tax Payback Period<sup>1</sup></b>	<b>Years</b>	<b>1.6</b>

1. Payback calculated from first production.

# MINERAL RESOURCE ESTIMATE

## Mineral Resource Estimate. Reported at cut-off of 1% Pb (Pb domains only).

- ✓ **Updated Mineral Resource Estimate** undertaken by independent consultants CSA Global Pty Ltd and reported to the ASX in June 2020.
- ✓ Demonstrates **the potential to incorporate more high-grade material** into the Sorby Hills Mine Plan.

Deposit	Measured				Indicated				Inferred				Total			
	Mt	Pb (%)	Ag (g/t)	Zn (%)	Mt	Pb (%)	Ag (g/t)	Zn (%)	Mt	Pb (%)	Ag (g/t)	Zn (%)	Mt	Pb (%)	Ag (g/t)	Zn (%)
A	-	-	-	-	-	-	-	-	0.6	6.1	32	1.2	<b>0.6</b>	<b>6.1</b>	<b>32</b>	<b>1.2</b>
B	0.5	4.3	24	0.3	1.3	4.2	24	0.3	-	-	-	-	<b>1.8</b>	<b>4.3</b>	<b>24</b>	<b>0.3</b>
Omega	4.2	4.3	45	0.4	9.2	3.2	29	0.4	2.5	3.0	23	0.6	<b>15.8</b>	<b>3.5</b>	<b>32</b>	<b>0.4</b>
Norton	2.4	4.3	83	0.3	2.2	3.4	38	0.5	16.0	2.5	30	0.4	<b>20.6</b>	<b>2.8</b>	<b>37</b>	<b>0.4</b>
Alpha	-	-	-	-	1.0	2.8	50	0.6	1.0	3.4	85	1.4	<b>2.0</b>	<b>3.1</b>	<b>67</b>	<b>1.0</b>
Beta	-	-	-	-	-	-	-	-	3.3	4.6	61	0.4	<b>3.3</b>	<b>4.6</b>	<b>61</b>	<b>0.4</b>
<b>Total</b>	<b>7.1</b>	<b>4.3</b>	<b>57</b>	<b>0.4</b>	<b>13.7</b>	<b>3.3</b>	<b>31</b>	<b>0.4</b>	<b>23.4</b>	<b>3.00</b>	<b>36</b>	<b>0.5</b>	<b>44.1</b>	<b>3.3</b>	<b>38</b>	<b>0.5</b>

The information presented above is extracted from the report entitled "Mineral Resource Update Sorby Hills Pb-Ag-Zn Project" released on 2 June 2020 and is available to view on [www.pacificominerals.com.au/](http://www.pacificominerals.com.au/).

## Contained Lead Metal and Resource Tonnage versus Cut-Off grade (Measured & Indicated Only).

- ✓ Contained Lead within the Measured and Indicated portion of the Resource is **only marginally susceptible to a change in cut-off grade.**
- ✓ The result demonstrates the **impressive robustness** of the Sorby Hills Resource.

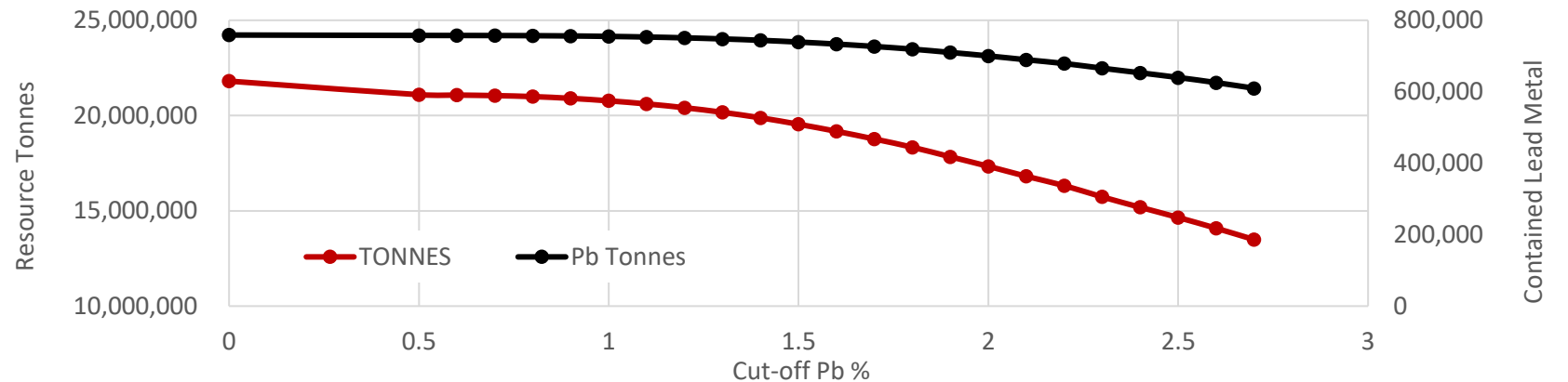

# BOARD AND MANAGEMENT

Experienced Board and Management with a proven track record in exploration and development.



**Gary Comb**  
Chairman

Engineer with over 30 years' experience in the Australian mining industry, with a strong track record in successfully commissioning and operating base metal mines.



**Simon Noon**  
Managing Director and CEO

Experienced executive with a strong background in strategic management, finance, capital raising and securing and operating joint ventures with mid to top tier miners in a variety of commodities.



**Richard Monti**  
Non-Exec. Director

Geologist with over 30 years' experience in technical, commercial, marketing and finance within the exploration and mining industry.



**Andrew Parker**  
Non-Exec. Director

Lawyer with extensive experience in the exploration and mining industry. Wealth of expertise in corporate advisory, strategic consultancy and vast experience in raising capital.

TECHNICAL TEAM	
<b>KEVIN REYNOLDS</b> Project Manager	Experienced metallurgist and project development manager of 30 years, covering mining and metallurgical operations, project development, process development, feasibility studies and project execution.
<b>SIMON DORLING</b> Exploration Manager	Geologist with more than 26 years' experience in exploration, development and the mining of base metals, precious metals, energy minerals and industrial minerals.



# EQUIVALENT CALCULATION

The contained metal equivalence formula is based on the Sorby Hills PFS including:

- Lead Price US\$2,095/t;
- Silver Price US\$21.1/oz;

## Lead Equivalent Calculations

- Silver recovery of 80.3% (weighted average of oxide and fresh Ag recoveries); and
- Silver Payability rate of 95%.

## Silver Equivalent Calculations

- Lead recovery of 93.3% (weighted average of oxide and fresh Pb recoveries); and
- Lead Payability rate of 95%.

It is Pacífico's opinion that all elements included in the metal equivalent calculation have a reasonable potential to be recovered and sold. The formula used to calculate lead equivalent grade is:

$$\text{Metal Eq (percent)} = G_{pri} + (G_{pri} \times [\sum_i R_i S_i V_i G_i] / (R_{pri} S_{pri} V_{pri} G_{pri}))$$

where **R** is the respective metallurgical metal recovery rate, **S** is the respective smelter return rate, **V** is metal price/tonne or ounce, and **G** is the metal commodity grade for the suite of potentially recoverable commodities (**i**) relative to the primary metal (**pri**).

Metal equivalents are highly dependent on the metal prices used to derive the formula. Pacífico notes that the metal equivalence method used above is a simplified approach. The metal prices are based on the PFS values adopted and do not reflect the metal prices that a smelter would pay for concentrate nor are any smelter penalties or charges included in the calculation.

Owing to limited metallurgical data, zinc grades are not included at this stage in the lead equivalent grade calculation.